

Site Inventory Form
State Historical Society of Iowa
 (November 2005)

State Inventory No. 09-00655 New Supplemental
 Part of a district with known boundaries (enter inventory no.) 09-00621
 Relationship: Contributing Noncontributing
 Contributes to a potential district with yet unknown boundaries
 National Register Status:(any that apply) Listed De-listed NHL DOE
 9-Digit SHPO Review & Compliance (R&C) Number _____
 Non-Extant (enter year) _____

1. Name of Property

historic name Empson, Walter and Dora, House

other names/site number _____

2. Location

street & number 322 2nd Ave NW

city or town Waverly vicinity, county Bremer

Legal Description: (If Rural) Township Name _____ Township No. _____ Range No. _____ Section _____ Quarter of Quarter _____

(If Urban) Subdivision Harmon and LeValley's Add Block(s) 39 Lot(s) Lot 5 EX S 74.56' E 16.58'

3. State/Federal Agency Certification [Skip this Section]

4. National Park Service Certification [Skip this Section]

5. Classification

Category of Property (Check only one box)

- building(s)
- district
- site
- structure
- object

Number of Resources within Property

<i>If Non-Eligible Property</i>		<i>If Eligible Property, enter number of:</i>	
Enter number of:		Contributing	Noncontributing
—	buildings	<u>1</u>	<u>1</u> buildings
—	sites	—	— sites
—	structures	—	— structures
—	objects	—	— objects
—	Total	<u>1</u>	<u>1</u> Total

Name of related project report or multiple property study (Enter "N/A" if the property is not part of a multiple property examination).

Title Waverly's NW & SE Neighborhoods Historical & Architectural Survey Historical Architectural Data Base Number 09-028

6. Function or Use

Historic Functions (Enter categories from instructions)

01A Single Dwelling

01C05 Garage

Current Functions (Enter categories from instructions)

01A Single Dwelling

01C05 Garage

7. Description

Architectural Classification (Enter categories from instructions)

09A05 Hipped Roof, 1-story

Materials (Enter categories from instructions)

foundation 10A Concrete Block

walls (visible material) 15B Vinyl

roof 08A Asphalt/Shingle

other _____

Narrative Description (SEE CONTINUATION SHEETS, WHICH MUST BE COMPLETED)

8. Statement of Significance

Applicable National Register Criteria (Mark "x" representing your opinion of eligibility after applying relevant National Register criteria)

- | | | |
|--|---|--|
| <input checked="" type="checkbox"/> Yes <input type="checkbox"/> No <input type="checkbox"/> More Research Recommended | A | Property is associated with significant events. |
| <input type="checkbox"/> Yes <input checked="" type="checkbox"/> No <input type="checkbox"/> More Research Recommended | B | Property is associated with the lives of significant persons. |
| <input checked="" type="checkbox"/> Yes <input type="checkbox"/> No <input type="checkbox"/> More Research Recommended | C | Property has distinctive architectural characteristics. |
| <input type="checkbox"/> Yes <input checked="" type="checkbox"/> No <input type="checkbox"/> More Research Recommended | D | Property yields significant information in archaeology or history. |

County Bremer
City Waverly

Address 322 2nd Ave NW

Site Number 09-00655
District Number 09-00621

Criteria Considerations

- A Owned by a religious institution or used for religious purposes.
- B Removed from its original location.
- C A birthplace or grave.
- D A cemetery.
- E A reconstructed building, object, or structure.
- F A commemorative property.
- G Less than 50 years of age or achieved significance within the past 50 years.

Areas of Significance (Enter categories from instructions)

02 ARCHITECTURE

Significant Dates

Construction date
1909 check if circa or estimated date
Other dates, including renovation
Garage – ca. 2010

Significant Person

(Complete if National Register Criterion B is marked above)

Architect/Builder

Architect

Builder

Narrative Statement of Significance (SEE CONTINUATION SHEETS, WHICH MUST BE COMPLETED)

9. Major Bibliographical References

Bibliography See continuation sheet for citations of the books, articles, and other sources used in preparing this form

10. Geographic Data

UTM References (OPTIONAL)

Zone	Easting	Northing	Zone	Easting	Northing
1	_____	_____	2	_____	_____
3	_____	_____	4	_____	_____

See continuation sheet for additional UTM references or comments

11. Form Prepared By

name/title Marlys Svendsen, Svendsen Tyler, Inc. date 10/2013
 organization for City of Waverly, Historic Preservation Commission telephone 715/469-3300
 street & number N3834 Deep Lake Road city or town Sarona state WI zip code 54870

ADDITIONAL DOCUMENTATION (Submit the following items with the completed form)

FOR ALL PROPERTIES

- Map:** showing the property's location in a town/city or township.
- Site plan:** showing position of buildings and structures on the site in relation to public road(s).
- Photographs:** representative black and white photos. If the photos are taken as part of a survey for which the Society is to be curator of the negatives or color slides, a photo/catalog sheet needs to be included with the negatives/slides and the following needs to be provided below on this particular inventory site:

Roll/slide sheet # _____	Frame/slot # _____	Date Taken _____
Roll/slide sheet # _____	Frame/slot # _____	Date Taken _____
Roll/slide sheet # _____	Frame/slot # _____	Date Taken _____

- See continuation sheet or attached *photo & slide catalog sheet* for list of photo roll or slide entries.
- Photos/illustrations without negatives are also in this site inventory file.

FOR CERTAIN KINDS OF PROPERTIES, INCLUDE THE FOLLOWING AS WELL

- Farmstead & District:** (List of structures and buildings, known or estimated year built, and contributing or noncontributing status)
- Barn:**
 - A sketch of the frame/truss configuration in the form of drawing a typical middle bent of the barn.
 - A photograph of the loft showing the frame configuration along one side.
 - A sketch floor plan of the interior space arrangements along with the barn's exterior dimensions in feet.

State Historic Preservation Office (SHPO) Use Only Below This Line

Concur with above survey opinion on National Register eligibility: Yes No More Research Recommended
 This is a locally designated property or part of a locally designated district.

Comments: _____

Evaluated by (name/title): _____ Date: _____

Iowa Site Inventory Form Continuation Sheet

Page 1

<u>Empson, Walter and Dora, House</u>	<u>Bremer</u>
Name of Property	County
<u>322 2nd Ave NW</u>	<u>Waverly</u>
Address	City

7. Description

This single-family house is estimated to have been built in 1905 according to Bremer County Assessor records. The house form and style are consistent with similar houses in Waverly built using this form from ca. 1890-1930. Property Transfer Records show this parcel transferred to W.J. Epsom by Charles Dittmer in 1909. Use of concrete block rather than stone confirms a post-1905 construction date. The 1913 city directory shows Walter Epsom and his wife Dora residing here. Public records suggest a construction date of ca. 1909.

This house is an example of a vernacular Hipped Roof, 1-story house form. The house has a rock-faced concrete block foundation and the walls are clad in narrow clapboard-style vinyl siding. The house has a steeply pitched hipped roof with narrow eaves. A gabled wall dormer is on the south façade above the front porch and a later shed-roof attic dormer is on the west façade. A broad gable-roofed enclosed porch spans most of the front façade. It has matching vinyl siding and a concrete block foundation on the walls with an entrance door centered between 1/1 windows. The porch was added after original construction and included 3/1 double-hung windows when built. In ca. 2010, the current wall finishes and windows were completed after the flood of 2008. Windows on the main house are 1/1 double-hung units.

The house has a 1-story detached double-bay garage constructed north of the house in ca. 2010. It has a front-gable roof, twin overhead doors and matching vinyl siding.

Alterations: vinyl siding (2010); porch enclosure, (2010); garage, (2010).

8. Significance

The Walter and Dora Empson House was built in ca. 1909 or slightly earlier and is an example of a vernacular Hipped Roof, 1-story house form. The house qualifies for the National Register of Historic Places as a contributing resource to the historic district under Criteria A and C.

Property Transfer Records show this parcel transferred to W.J. Epsom by Charles Dittmer in 1909. By 1913, Walter Empson and his wife Dora resided here. Walter had no occupation at the time making it possible that the couple were retired. In 1944, the property passed to Blanche Gaffney who held it until after she married and became Blanche Perkins. She sold it in 1945 to John and Yvonne Gambaiani. They held it until 1950 when it was sold to Louis and Darlen Gambaiani who held it for some years.

9. Sources

Atlas of Bremer County, Iowa. Waverly, Iowa: Waverly Publishing Company, 1917.

Atlases of Bremer County. Microfilm copies of atlases for 1875, 1894 and 1927, Waverly Public Library.

Property Reports, Bremer County Assessor's Office.

Iowa Department of Cultural Affairs
State Historical Society of Iowa
**Iowa Site Inventory Form
Continuation Sheet**

Site Number 09-00655
Related District Number 09-00621

Page 2

<u>Empson, Walter and Dora, House</u>	<u>Bremer</u>
Name of Property	County
<u>322 2nd Ave NW</u>	<u>Waverly</u>
Address	City

Bremer County History Book Committee. *Bremer County History, 1985*. Dallas, Texas: Taylor Publishing, 1985.

Grawe, Joseph F. *History of Bremer County, Iowa, Volumes I and II*. Chicago: S.J. Clarke Company, 1914.

History of Butler and Bremer Counties, Iowa. Springfield, Illinois: Union Publishing, 1883.

Property Transfer Records, Bremer County Auditor's Office.

Sanborn Company Maps. New York: Sanborn Map Company, 1885, 1892, 1897, 1905, 1915, 1927, and 1927 updated to 1943.

Waverly building histories, miscellaneous bound volumes in reference collection, Waverly Public Library.

Waverly city directories, 1899 and 1913.

Waverly Heritage Days historical walking tour brochures for 1995, 1996, 1997, 1998, 1999 and 2000.

Waverly Historic Photo Collection, Waverly Public Library.

Iowa Department of Cultural Affairs
State Historical Society of Iowa
**Iowa Site Inventory Form
Continuation Sheet**

Site Number 09-00655
Related District Number 09-00621

Page 3

Empson, Walter and Dora, House	Bremer
Name of Property	County
322 2 nd Ave NW	Waverly
Address	City

Site Map: Bremer County GIS Department, 12/2011.

**322 2nd Ave NW
PIN 09-03-240-002**



Iowa Department of Cultural Affairs
State Historical Society of Iowa
**Iowa Site Inventory Form
Continuation Sheet**

Site Number 09-00655
Related District Number 09-00621

Page 4

Empson, Walter and Dora, House

Bremer

Name of Property

County

322 2nd Ave NW

Waverly

Address

City

Photographs: 322 2nd Ave NW, looking northeast and northwest, Marlys Svendsen, photographer, 11/16/2011.



Iowa Department of Cultural Affairs
State Historical Society of Iowa
**Iowa Site Inventory Form
Continuation Sheet**

Site Number 09-00655
Related District Number 09-00621

Page 5

Empson, Walter and Dora, House

Bremer

Name of Property

County

322 2nd Ave NW

Waverly

Address

City

Photographs: 322 2nd Ave NW, garage, looking southeast, Marlys Svendsen, photographer, 11/16/2011.



Iowa Department of Cultural Affairs
State Historical Society of Iowa
**Iowa Site Inventory Form
Continuation Sheet**

Site Number 09-00655
Related District Number 09-00621

Page 6

Empson, Walter and Dora, House

Bremer

Name of Property

County

322 2nd Ave NW

Waverly

Address

City

Photographs: 322 2nd Ave NW, looking northeast, Justine Zimmer, IHSEMD, photographer, 4/24/2009.



Iowa Department of Cultural Affairs
 State Historical Society of Iowa
Iowa Site Inventory Form
Continuation Sheet

Site Number 09-00655
 Related District Number 09-00621

Page 7

Empson, Walter and Dora, House	Bremer
Name of Property	County
322 2 nd Ave NW	Waverly
Address	City

Floor Plan: Bremer County Assessor's website; available at: <http://beacon.schneidercorp.com/PhotoEngine/Sketch.aspx?appid=330&keyvalue=0903240002&index=0&size=0>; accessed 11/12/2012.

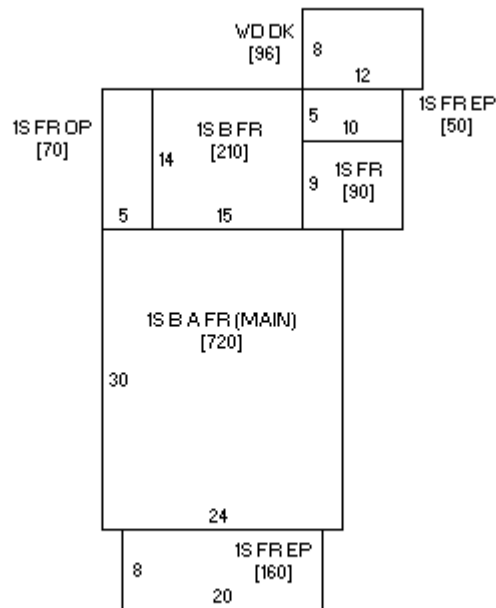

Sketch by www.camavision.com