

**Site Inventory Form**  
**State Historical Society of Iowa**  
 (November 2005)

State Inventory No. 09-00646

New  Supplemental

Part of a district with known boundaries (enter inventory no.) 09-00621

Relationship:  Contributing  Noncontributing

Contributes to a potential district with yet unknown boundaries

National Register Status:(any that apply)  Listed  De-listed  NHL  DOE

9-Digit SHPO Review & Compliance (R&C) Number \_\_\_\_\_

Non-Extant (enter year) \_\_\_\_\_

**1. Name of Property**

historic name Eckstein, John and Julia, House

other names/site number \_\_\_\_\_

**2. Location**

street & number 603 1<sup>st</sup> St NW

city or town Waverly

vicinity, county Bremer

Legal Description: (If Rural) Township Name \_\_\_\_\_ Township No. \_\_\_\_\_ Range No. \_\_\_\_\_ Section \_\_\_\_\_ Quarter of Quarter \_\_\_\_\_

(If Urban) Subdivision J.J. Smith's Add.

Block(s) 7

Lots Lot 8

**3. State/Federal Agency Certification [Skip this Section]**

**4. National Park Service Certification [Skip this Section]**

**5. Classification**

Category of Property (Check only one box)

- building(s)
- district
- site
- structure
- object

Number of Resources within Property

If Non-Eligible Property		If Eligible Property, enter number of:	
Enter number of:		Contributing	Noncontributing
—	buildings	<u>1</u>	<u>1</u> buildings
—	sites	—	— sites
—	structures	—	— structures
—	objects	—	— objects
—	Total	<u>1</u>	<u>1</u> Total

Name of related project report or multiple property study (Enter "N/A" if the property is not part of a multiple property examination).

Title Waverly's NW & SE Neighborhoods Historical & Architectural Survey

Historical Architectural Data Base Number 09-028

**6. Function or Use**

Historic Functions (Enter categories from instructions)

Current Functions (Enter categories from instructions)

01A Single Dwelling

01A Single Dwelling

01C05 Garage

01C05 Garage

**7. Description**

Architectural Classification (Enter categories from instructions)

Materials (Enter categories from instructions)

09A02 Gable-Front and Wing (2-story)

foundation 10A Concrete Block

walls (visible material) 15B Vinyl

roof 08A Asphalt/Shingle

other \_\_\_\_\_

**Narrative Description** ( SEE CONTINUATION SHEETS, WHICH MUST BE COMPLETED)

**8. Statement of Significance**

Applicable National Register Criteria (Mark "x" representing your opinion of eligibility after applying relevant National Register criteria)

- |  |   |  |
|--|---|--|
| <input checked="" type="checkbox"/> Yes <input type="checkbox"/> No <input type="checkbox"/> More Research Recommended | A | Property is associated with significant events.                    |
| <input type="checkbox"/> Yes <input checked="" type="checkbox"/> No <input type="checkbox"/> More Research Recommended | B | Property is associated with the lives of significant persons.      |
| <input checked="" type="checkbox"/> Yes <input type="checkbox"/> No <input type="checkbox"/> More Research Recommended | C | Property has distinctive architectural characteristics.            |
| <input type="checkbox"/> Yes <input checked="" type="checkbox"/> No <input type="checkbox"/> More Research Recommended | D | Property yields significant information in archaeology or history. |

County Bremer  
City Waverly

Address 603 1<sup>st</sup> St NW

Site Number 09-00646  
District Number 09-00621

**Criteria Considerations**

- A Owned by a religious institution or used for religious purposes.
- B Removed from its original location.
- C A birthplace or grave.
- D A cemetery.
- E A reconstructed building, object, or structure.
- F A commemorative property.
- G Less than 50 years of age or achieved significance within the past 50 years.

**Areas of Significance** (Enter categories from instructions)

02 ARCHITECTURE

**Significant Dates**

Construction date  
1903  check if circa or estimated date  
Other dates, including renovation  
Garage – 1999

**Significant Person**

(Complete if National Register Criterion B is marked above)

**Architect/Builder**

Architect

Builder

**Narrative Statement of Significance** ( SEE CONTINUATION SHEETS, WHICH MUST BE COMPLETED)

**9. Major Bibliographical References**

Bibliography  See continuation sheet for citations of the books, articles, and other sources used in preparing this form

**10. Geographic Data**

UTM References (OPTIONAL)

Zone	Easting	Northing	Zone	Easting	Northing
1	_____	_____	2	_____	_____
3	_____	_____	4	_____	_____

See continuation sheet for additional UTM references or comments

**11. Form Prepared By**

name/title Marlys Svendsen, Svendsen Tyler, Inc.  
organization for City of Waverly, Historic Preservation Commission  
street & number N3834 Deep Lake Road  
city or town Sarona state WI date 9/2013  
telephone 715/469-3300 zip code 54870

**ADDITIONAL DOCUMENTATION** (Submit the following items with the completed form)

**FOR ALL PROPERTIES**

- Map:** showing the property's location in a town/city or township.
- Site plan:** showing position of buildings and structures on the site in relation to public road(s).
- Photographs:** representative black and white photos. If the photos are taken as part of a survey for which the Society is to be curator of the negatives or color slides, a photo/catalog sheet needs to be included with the negatives/slides and the following needs to be provided below on this particular inventory site:

Roll/slide sheet # _____	Frame/slot # _____	Date Taken _____
Roll/slide sheet # _____	Frame/slot # _____	Date Taken _____
Roll/slide sheet # _____	Frame/slot # _____	Date Taken _____

- See continuation sheet or attached *photo & slide catalog sheet* for list of photo roll or slide entries.
- Photos/illustrations without negatives are also in this site inventory file.

**FOR CERTAIN KINDS OF PROPERTIES, INCLUDE THE FOLLOWING AS WELL**

- Farmstead & District:** (List of structures and buildings, known or estimated year built, and contributing or noncontributing status)
- Barn:**
  - A sketch of the frame/truss configuration in the form of drawing a typical middle bent of the barn.
  - A photograph of the loft showing the frame configuration along one side.
  - A sketch floor plan of the interior space arrangements along with the barn's exterior dimensions in feet.

**State Historic Preservation Office (SHPO) Use Only Below This Line**

Concur with above survey opinion on National Register eligibility:  Yes  No  More Research Recommended  
 This is a locally designated property or part of a locally designated district.

Comments: \_\_\_\_\_

Evaluated by (name/title): \_\_\_\_\_ Date: \_\_\_\_\_

# Iowa Site Inventory Form Continuation Sheet

Page 1

---

Eckstein, John and Julia, House

Bremer

Name of Property

County

603 1<sup>st</sup> St NW

Waverly

Address

City

---

## 7. Description

This single-family house is estimated to have been built in 1903 according to Bremer County Assessor records. The house form and style are consistent with houses in Waverly built from the 1880s through the 1920s. Property transfer records show this parcel acquired by John Eckstein in June 1898 and the 1899 city directory shows him residing at 603 W. Water Street (1<sup>st</sup> St NW). A construction date of ca. 1903 is consistent with public records for this property.

This 2-story frame house is an example of a vernacular Gable-Front-and-Wing house form. The house has a concrete block foundation with narrow clapboard-style vinyl siding on the walls. The steeply pitched cross-gable roof has shallow eaves and gabled wall dormers on the east façade of the north wing and the upper level of the south façade. A hipped roof 1-story addition is at the northwest corner of the house. An enclosed, shed-roofed porch fills the right-hand ell. It has matching siding and a concrete foundation. Fenestration throughout the house includes widely spaced, single 1/1 double-hung windows. The exception is a new by-pass window in the enclosed front porch.

A double-bay frame garage is located north of the house. It was originally built in 1999 according to Assessor records. It has a low-pitched side-gable roof with narrow clapboard-style vinyl siding on the walls.

Alterations: vinyl siding on house (undated); front porch enclosed (undated).

## 8. Significance

The John and Julia Eckstein House at 603 1<sup>st</sup> St NW was built in ca. 1903 as a retirement home for the Ecksteins and is an example of a vernacular Gable-Front-and-Wing house form. The house qualifies for the National Register of Historic Places as a contributing resource to the historic district under Criteria A and C. The garage is considered noncontributing because of integrity issues.

John Eckstein acquired this lot in June 1898 from Charles Krause. By the time the 1899 city directory was published, he was listed as residing at this address. John and his wife Julia continued to be listed at this address in the 1913 city directory. In both cases, John was listed as "retired." John was born in 1840 and died in 1923. He and his wife Julia had six daughters and six sons before retiring to this house in ca. 1903. The couple is buried at St. Paul's Lutheran Cemetery in Washington Township. Sometime after 1913, the house was transferred to Katherine Geissendoerfer, a widow, who passed it to Fred "Fritz" Ochlschlager in 1922. Alma Ochlschlager in turn transferred the property to Adolph Hartman in 1932. Adolph died in 1935 and property passed to Wilhelmina Hartmann. She retained ownership until 1972 but appears to have lived elsewhere in the neighborhood..

## 9. Sources

*Atlas of Bremer County, Iowa.* Waverly, Iowa: Waverly Publishing Company, 1917.

*Atlases of Bremer County.* Microfilm copies of atlases for 1875, 1894 and 1927, Waverly Public Library.

# Iowa Site Inventory Form Continuation Sheet

Page 2

---

Eckstein, John and Julia, House

Bremer

Name of Property

County

603 1<sup>st</sup> St NW

Waverly

Address

City

---

Bremer County History Book Committee. *Bremer County History, 1985*. Dallas, Texas: Taylor Publishing, 1985.

Grawe, Joseph F. *History of Bremer County, Iowa, Volumes I and II*. Chicago: S.J. Clarke Company, 1914.

*History of Butler and Bremer Counties, Iowa*. Springfield, Illinois: Union Publishing, 1883.

Property Reports, Bremer County Assessor's Office

Property Transfer Records, Bremer County Auditor's Office.

Sanborn Company Maps. New York: Sanborn Map Company, 1885, 1892, 1897, 1905, 1915, 1927, and 1927 updated to 1943.

Vertical file collection, Waverly Public Library.

Waverly building histories, miscellaneous bound volumes in reference collection, Waverly Public Library.

Waverly Business News Index (database), Waverly Public Library.

Waverly city directories, 1899 and 1913.

Waverly Heritage Days historical walking tour brochures for 1995, 1996, 1997, 1998, 1999 and 2000.

Waverly Historic Photo Collection, Waverly Public Library.

Iowa Department of Cultural Affairs  
State Historical Society of Iowa  
**Iowa Site Inventory Form  
Continuation Sheet**

Site Number 09-00646  
Related District Number 09-001

Page 3

Eckstein, John and Julia, House  
Name of Property  
603 1<sup>st</sup> St NW  
Address

Bremer  
County  
Waverly  
City

Site Map: Bremer County GIS Department, 12/2011.

**603 1st St NW  
PIN 05-35-362-008**

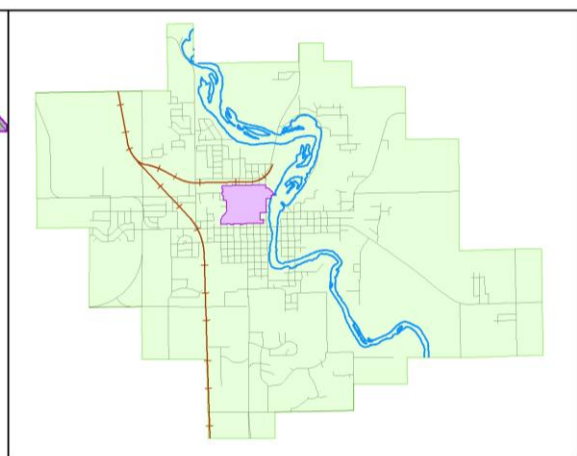



Iowa Department of Cultural Affairs  
State Historical Society of Iowa  
**Iowa Site Inventory Form  
Continuation Sheet**

Site Number 09-00646  
Related District Number 09-001

Page 4

Eckstein, John and Julia, House

Bremer

Name of Property

County

603 1<sup>st</sup> St NW

Waverly

Address

City

**Photographs:** 603 1<sup>st</sup> St NW, looking southwest and northwest, Marlys Svendsen, Svendsen Tyler, Inc., photographer, 11/3/2011.



Iowa Department of Cultural Affairs  
State Historical Society of Iowa  
**Iowa Site Inventory Form  
Continuation Sheet**

Site Number 09-00646  
Related District Number 09-001

Page 5

Eckstein, John and Julia, House

Bremer

Name of Property

County

603 1<sup>st</sup> St NW

Waverly

Address

City

**Photographs:** 603 1<sup>st</sup> St NW, garage, looking northwest, Marlys Svendsen, Svendsen Tyler, Inc., photographer, 11/3/2011.





# Iowa Site Inventory Form Continuation Sheet

Page 6

Eckstein, John and Julia, House

Bremer

Name of Property

County

603 1<sup>st</sup> St NW

Waverly

Address

City

**Photographs:** 603 1<sup>st</sup> St NW, looking northwest and southwest, Justine Zimmer, IHSEMD, photographer, 4/24/2009.





# Iowa Site Inventory Form Continuation Sheet

Page 7

Eckstein, John and Julia, House

Bremer

Name of Property

County

603 1<sup>st</sup> St NW

Waverly

Address

City

### Additional Information:

Floor plan, 603 1<sup>st</sup> St NW, Bremer County Assessor website; available at <http://beacon.schneidercorp.com/PhotoEngine/Sketch.aspx?appid=330&keyvalue=0535362008&index=0&size=0>; 10/22/2012.

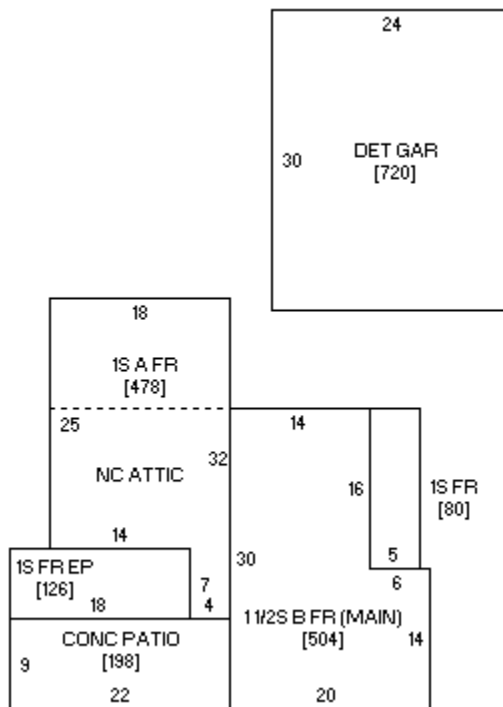

Sketch by [www.camavision.com](http://www.camavision.com)